



# working with data

teacher's guide

**Editors:**

Brian A. Jerome Ph.D.  
Stephanie Zak Jerome

**Assistant Editors:**

Louise Marrier  
Josh Hummel

## a message from our company . . .

Visual Learning is a Vermont-based, family owned company specializing in the creation of science programs. As former classroom science teachers, we have designed our programs to meet the needs and interests of both students and teachers. Our mission is to help educators and students meet educational goals while experiencing the thrill of science!

### viewing clearances

The video and accompanying teacher's guide are for instructional use only. In showing these programs, no admission charges are to be incurred. The programs are to be utilized in face-to-face classroom instructional settings, library settings, or similar instructional settings.

Duplication rights are available, but must be negotiated with visual learning systems.

Television, cable, or satellite rights are also available, but must be negotiated with visual learning systems.

Closed circuit rights are available, and are defined as the use of the program beyond a single classroom but within a single campus. Institutions wishing to utilize the program in multiple campuses must purchase the multiple campus version of the program, available at a slightly higher fee.

Video streaming rights are available and must be negotiated with visual learning systems.

Discounts may be granted to institutions interested in purchasing programs in large quantities. These discounts may be negotiated with visual learning systems.

### use and copyright

The purchase of this video program entitles the user the right to reproduce or duplicate, in whole or in part, this teacher's guide and the black line master handouts for the purpose of teaching in conjunction with this video, *working with data*. The right is restricted only for use with this video program. Any reproduction or duplication, in whole or in part, of this guide and student masters for any purpose other than for use with this video program is prohibited.

The video and this teacher's guide are the exclusive property of the copyright holder. Copying, transmitting, or reproducing in any form, or by any means, without prior written permission from the copyright holder is prohibited (Title 17, U.S. Code Sections 501 and 506).

Copyright © 2014

ISBN 978-1-59234-909-8

## teacher's guide

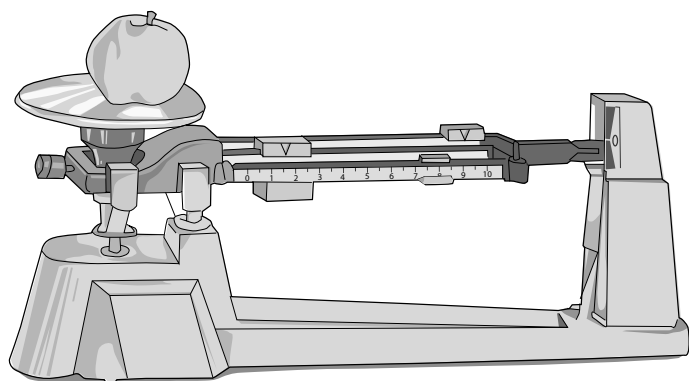

a message from our company	2
viewing clearances	2
use and copyright	2
student learning objectives	4
assessment	4
introducing the program	5
program viewing suggestions	5
literature connections	5
key vocabulary	6
video script	6
answer key to student assessments	9
answer key to student activities	9

## student activities

what do you know now?	10
what have you learned?	11
video review	12
video quiz	12
tools and measuring	13
you measure	14
showing data	15

# student learning objectives

Upon viewing the video and completing the enclosed student activities, students will be able to do the following:

- 1 Know that an observation is information we get from our surroundings using our senses.
- 2 Understand there are many different ways observations are recorded.
- 3 Define data as recorded observations that can be shared.
- 4 Describe measuring as a way to make observations with the use of numbers.
- 5 Explain that tools and other devices are often needed to make measurements.
- 6 Provide an example of something that is measured and describe how it is measured.
- 7 Understand that when things are measured, numbers are often recorded as data.
- 8 Know that a graph is a way of showing data.
- 9 When provided with a graph, explain how it represents data.

## assessment

### **what do you know now? (p. 10):**

This preliminary assessment is an assessment tool designed to gain an understanding of students' preexisting knowledge. It can also be used as a benchmark upon which to assess student progress based on the objectives stated on the previous pages.

### **what have you learned? (p. 11):**

This post assessment can be utilized as an assessment tool following student completion of the program and student activities. The results of this assessment can be compared against the results of the preliminary assessment to assess student progress.

### **video review (p. 12):**

The video review can be used as an assessment tool or as a student activity. There are two sections. The first part contains questions displayed during the program. The second part consists of a five-question video quiz to be answered at the end of the video.

## introducing the program

Before showing students the program, as a class you will make some observations and generate some data. To obtain your data you could observe and record the various types of hair color in the class. Or, you could measure and record the height of each student. Or, you could record the color of each student's shirt/blouse. Any of these observations will generate data that you can record on the board in an organized way.

Next, ask students how this data could be shown in a way that makes it easier to understand. One simple way is to place it into logical groupings on the board or to put it into a data table. Write the term “graph” on the board. Explain that graphs are one way of showing data. Make a graph using the data collected by the class. Tell students to pay close attention to the video to learn more about working with data.

## program viewing suggestions

The student master “video review” is provided (p. 12) for distribution to students. You may choose to have your students complete this master while viewing the program or do so upon its conclusion.

The program is approximately 10 to 12 minutes in length and includes a five-question video quiz. Answers are not provided to the video quiz in the video, but are included in this guide on page 9. You may choose to grade student quizzes as an assessment tool or to review the answers in class.

The video is content-rich with numerous vocabulary words. For this reason you may want to periodically stop the video to review and discuss new terminology and concepts.

## literature connections

Besel, Jennifer M. *Lions and Tigers and Graphs: Oh My!* North Mankato: Capstone Press, 2011.

Burn, Kylie. *What's Going On? Collecting and Recording Your Data*. New York: Crabtree Publishing Company, 2010.

Leedy, Loreen. *The Great Graph Contest*. New York: Holiday House, 2006.

Roca, Nuria. *The 5 Senses*. Hauppauge: Barron's Educational, 2006.

Thompson, Lisa. *What's Next?* North Mankato: Picture Window Books, 2005.

## key vocabulary

observation  
senses

data  
measuring

recorded  
graph

## video script

### 1

#### 01 introduction

- 02 Have you ever kept score in a game?  
 03 Maybe you've had to count money to buy something.  
 04 Or, perhaps you've had to follow a recipe to bake some food.  
 05 These are all examples of ways people work with data.  
 06 What exactly is data?  
 07 What are some of the different types of data?  
 08 How do people obtain data?  
 09 And, what are some of the ways data can be shown?  
 10 During the next few minutes we are going to answer these questions, and others, ...  
 11 ... as we go about working with data.

### 2

#### 12 observing data

you  
observe

#### 13 What happened when this soda was opened?

- 14 That's right it exploded.  
 15 You know that the soda exploded because you could see it and hear it.  
 16 This is an example of an observation.  
 17 An **observation** is information we get from our surroundings using our senses.  
 18 We use our **senses** of sight, smell, touch, hearing and taste to make observations.  
 19 For example, you know that a train is passing by because you can see it and hear it.  
 20 Sometimes we record our observations.  
 21 For example, we can record this sunset by taking a picture of it.  
 22 Or, you can record your height by writing it down on a piece of paper.  
 23 Observations that are recorded, are called **data**.  
 24 Data is very important in science and engineering.

### 3 25 measuring and data

**you  
decide**

26 **How long is this paper clip?**

27 That's right, it is about three centimeters long.

28 We used a ruler to measure the length of the paper clip.

29 Measuring is one way to make observations.

30 **Measuring** is a way of making observations with the use of numbers. Tools and other devices are usually needed to measure things.

31 We measure things such as weight and time very frequently.

32 Measuring is an important way for scientists and engineers to make observations.

### 4 33 recording data

34 If you want to show your friend who lives across the country what your home looks like, you would send her a photo.

35 Or, if you want to show how well your soccer team played a game, you would send a video.

36 These are examples of ways data is recorded.

37 When data is **recorded**, it is saved in a way so other people can observe it.

38 When things are measured, numbers are recorded as data.

39 For example, if you measured the daily high temperature with a thermometer three days in a row, you could record the temperature readings by writing the numbers on a piece of paper.

40 This data is recorded in degrees Celsius.

41 This is just one of the many ways that data can be recorded.

### 5 42 showing data

43 Perhaps you have heard someone say: "A picture paints a thousand words".

44 This is a fun thing about data - it can be made into images that are like pictures.

**you  
decide**

45 **What's this?**

46 That's right it's a graph

47 A **graph** is a way to display data. It's a type of picture that represents data.

48 Let's see how this is done. Using our three days of temperature readings, we can put the data into a type of graph called a bar graph.

49 Each bar represents the high temperature on a different day.

50 Notice how easy it is to see the day that was the warmest.

51 There are many different types of graphs.

- 52 There are also other ways data can be shown.  
53 For example, this image of the ocean taken from a satellite shows areas of various water temperature.  
54 Each color represents different temperatures recorded by the satellite.  
55 Data can be shown in many fascinating ways.

**6****video review**

- 57 During the past few minutes we explored the process of working with data  
58 We began by reviewing how we use our senses to make observations.  
59 And we saw how data is gathered and observations are recorded.  
60 Data often is the result of recording measurements.  
61 Numbers are common types of data obtained by measuring.  
62 Often data is recorded by writing it down.  
63 Last we saw how data can be shown in the form of graphs.  
64 This rounded out our fascinating exploration of working with data.

**7****video quiz**

- 66 Fill in the correct word to complete the sentence.  
67 1. An \_\_\_\_\_ is information we get from our surroundings.  
68 2. Recorded observations are called \_\_\_\_\_.  
69 3. Measuring involves making observations by using \_\_\_\_\_.  
70 4. When data is \_\_\_\_\_ it is saved.  
71 5. This is a \_\_\_\_\_.

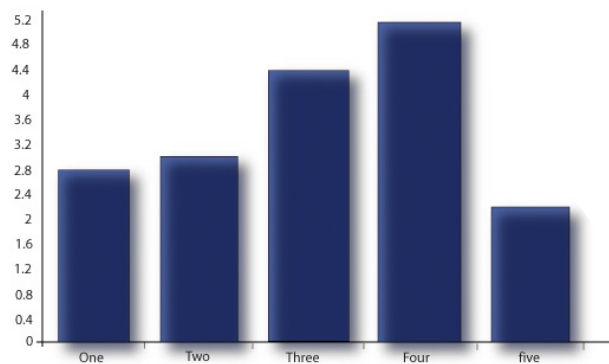

# answer key to student assessments

## what do you know now?

- 1 our senses
- 2 hearing
- 3 data
- 4 sight
- 5 observations
- 6 numbers
- 7 temperature
- 8 ruler
- 9 saved
- 10 shown

## video review (p. 12)

- 1 The soda exploded when it was opened.
- 2 The paper clip is about three centimeters long.
- 3 It is a graph.

## what have you learned? (p. 11)

- 1 shown
- 2 numbers
- 3 our senses
- 4 temperature
- 5 data
- 6 sight
- 7 hearing
- 8 ruler
- 9 observation
- 10 saved

## video quiz (p. 12)

- 1 observation
- 2 data
- 3 numbers
- 4 recorded
- 5 graph

# answer key to student activities

## tools and measuring (p. 13)

- 1 This ruler measures the length of objects. Rulers are used to measure the length of string and paper.
- 2 This scale measures the weight of objects. It can be used to measure the weight of candy, fruits, and other foods.
- 3 This beaker is used to measure the volume of liquids. It can be used to measure liquids in the science lab.

## you measure (p. 14)

- 1 The answers will vary depending on the length of the straws.

## showing data (p. 15)

The students' graphs will vary depending on their measurements of the straws.

- 1 A ruler was used to measure straw length.
- 2 A graph is a type of picture that represents data. A graph is a way to describe data.
- 3 The students' answers will vary.

# what do you know now?

Name: \_\_\_\_\_

Select the best answer for each of the following questions.

**1** What do we use to make observations?

- paper and pencils
- computers
- our senses
- knowledge

**2** To observe loudness we use what sense?

- taste
- smell
- hearing
- touch

**3** Observations that are recorded are called:

- data
- ditto
- language
- words

**4** To observe the color of something we use what sense?

- hearing
- sight
- taste
- smell

**5** Measuring is a way of making what?

- observations
- work
- experiments
- money

**6** When making measurements, what is often recorded?

- sounds
- numbers
- nothing
- smells

**7** What type of data does a thermometer produce?

- length
- size
- weight
- temperature

**8** What tool is used to measure the length of a paper clip?

- scale
- ruler
- microscope
- hammer

**9** When data is recorded, it is:

- lost
- changed
- saved
- forgotten

**10** A graph is a way data can be:

- shown
- changed
- subtracted
- added

# what have you learned?

Name: \_\_\_\_\_

Select the best answer for each of the following questions.

**1** A graph is a way data can be:

- shown
- changed
- subtracted
- added

**2** When making measurements, what is often recorded?

- sounds
- numbers
- nothing
- smells

**3** What do we use to make observations?

- paper and pencils
- computers
- our senses
- knowledge

**4** What type of data does a thermometer provide?

- length
- size
- weight
- temperature

**5** Observations that are recorded are called:

- data
- ditto
- language
- words

**6** To observe the color of something we use what sense?

- hearing
- sight
- taste
- smell

**7** To observe loudness we use what sense?

- taste
- smell
- hearing
- touch

**8** What tool would be best to measure the length of a paper clip?

- scale
- ruler
- microscope
- hammer

**9** Measuring is a way of making what?

- observations
- work
- experiments
- money

**10** When data is recorded, it is:

- lost
- changed
- saved
- forgotten

# video review

Name: \_\_\_\_\_



## You Observe

What happened when this soda was opened?

---

---

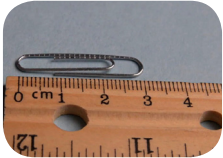

## You Decide

How long is this paper clip?

---

---

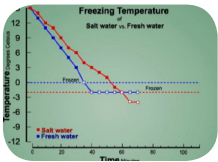

## You Decide

What's this?

---

---

# video quiz



An \_\_\_\_\_ is information we get from our surroundings.

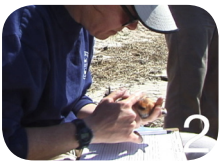

Recorded observations are called \_\_\_\_\_.

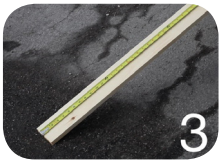

Measuring involves making observations by using \_\_\_\_\_.



When data is \_\_\_\_\_ it is saved.

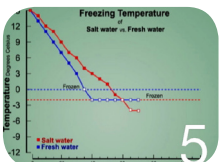

This is a \_\_\_\_\_.

# tools and measuring

Name: \_\_\_\_\_

Measuring is one way to make observations. Measuring is a way of making observations with the use of numbers. Tools and other devices are often needed to measure things.

**Directions:** Describe what each tool measures. Provide an example of what it is used to measure.

## Tool

## What does it measure?

1



---

---

---

---

2

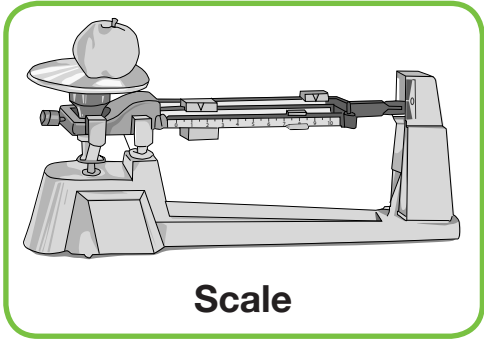

---

---

---

---

3



---

---

---

---

# you measure

Name: \_\_\_\_\_

When data is recorded it is often written down. When data is recorded other people can read and understand it.

## Directions:

- 1 Get a metric ruler from your teacher. A ruler is a tool used to measure length.
- 2 Measure the length of five different straws.
- 3 Record these measurements in the data table below.



Straw	Length in centimeters
#1	
#2	
#3	
#4	
#5	

# showing data

Name:	_____
-------	-------

**Directions:** A graph is a way to describe data. It is a type of picture that represents data. Make a bar graph from the data you measured of straw length. Use colored pencils.

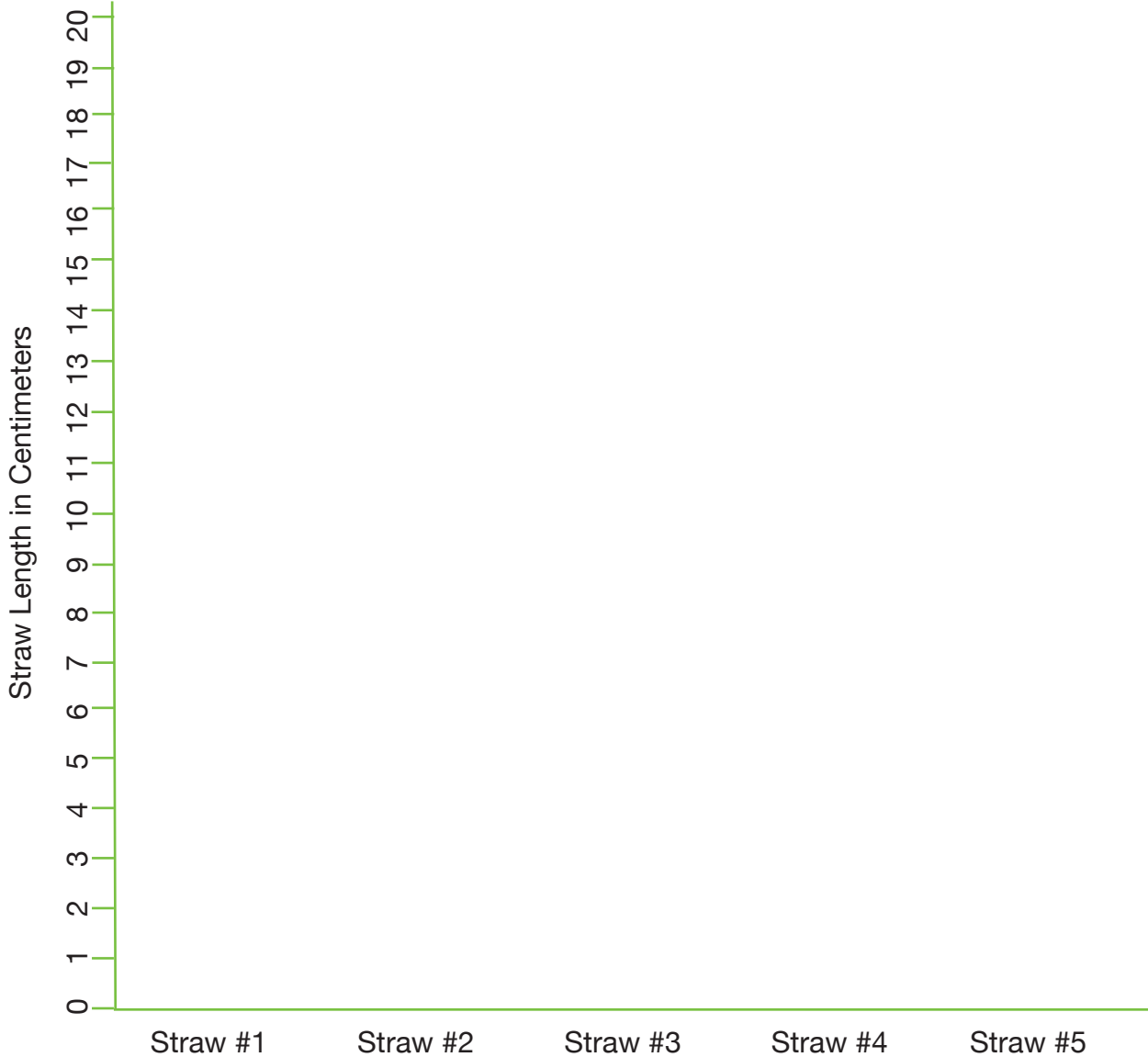

### Questions:

- 1 What tool was used to measure straw length? \_\_\_\_\_
- 2 What is a graph? \_\_\_\_\_  
\_\_\_\_\_
- 3 Which straw was the longest? How long was it? \_\_\_\_\_  
\_\_\_\_\_